



**ASCENT**<sup>®</sup>  
CENTER FOR TECHNICAL KNOWLEDGE

# **AutoCAD<sup>®</sup> 2023**

## **3D Drawing and Modeling**

*Learning Guide*  
*Mixed Units - 1<sup>st</sup> Edition*

 **AUTODESK**  
Authorized Publisher

---

**ASCENT - Center for Technical Knowledge®**  
**AutoCAD® 2023**  
**3D Drawing and Modeling**  
Mixed Units - 1<sup>st</sup> Edition

Prepared and produced by:

ASCENT Center for Technical Knowledge  
630 Peter Jefferson Parkway, Suite 175  
Charlottesville, VA 22911

866-527-2368  
www.ASCENTed.com

Lead Contributor: Renu Muthoo



ASCENT - Center for Technical Knowledge (a division of Rand Worldwide Inc.) is a leading developer of professional learning materials and knowledge products for engineering software applications. ASCENT specializes in designing targeted content that facilitates application-based learning with hands-on software experience. For over 25 years, ASCENT has helped users become more productive through tailored custom learning solutions.

We welcome any comments you may have regarding this guide, or any of our products. To contact us please email: [feedback@ASCENTed.com](mailto:feedback@ASCENTed.com).

© ASCENT - Center for Technical Knowledge, 2022

All rights reserved. No part of this guide may be reproduced in any form by any photographic, electronic, mechanical or other means or used in any information storage and retrieval system without the written permission of ASCENT, a division of Rand Worldwide, Inc.

The following are registered trademarks or trademarks of Autodesk, Inc., and/or its subsidiaries and/or affiliates in the USA and other countries: 123D, 3ds Max, ADSK, Alias, ATC, AutoCAD LT, AutoCAD, Autodesk, the Autodesk logo, Autodesk 123D, Autodesk Alias, Autodesk Docs, ArtCAM, Autodesk Forge, Autodesk Fusion, Autodesk Inventor, AutoSnap, BIM 360, Buzzsaw, CADmep, CAMduct, Civil 3D, Configurator 360, Dancing Baby (image), DWF, DWG, DWG (DWG logo), DWG Extreme, DWG TrueConvert, DWG TrueView, DWGX, DXF, Eagle, ESTmep, FBX, FeatureCAM, Flame, FormIt 360, Fusion 360, The Future of Making Things, Glue, Green Building Studio, InfraWorks, Instructables, Instructables (Instructables logo), Inventor, Inventor CAM, Inventor HSM, Inventor LT, Make Anything, Maya, Maya LT, Moldflow, MotionBuilder, Mudbox, Navisworks, Netfabb, Opticore, PartMaker, Pier 9, PowerInspect, PowerMill, PowerShape, Publisher 360, RasterDWG, RealDWG, ReCap, ReCap 360, Remake, Revit LT, Revit, Scaleform, Shotgun, Showcase, Showcase 360, SketchBook, Softimage, Tinkercad, TrustedDWG, VRED.

NASTRAN is a registered trademark of the National Aeronautics Space Administration.

All other brand names, product names, or trademarks belong to their respective holders.

General Disclaimer:

Notwithstanding any language to the contrary, nothing contained herein constitutes nor is intended to constitute an offer, inducement, promise, or contract of any kind. The data contained herein is for informational purposes only and is not represented to be error free. ASCENT, its agents and employees, expressly disclaim any liability for any damages, losses or other expenses arising in connection with the use of its materials or in connection with any failure of performance, error, omission even if ASCENT, or its representatives, are advised of the possibility of such damages, losses or other expenses. No consequential damages can be sought against ASCENT or Rand Worldwide, Inc. for the use of these materials by any third parties or for any direct or indirect result of that use.

The information contained herein is intended to be of general interest to you and is provided "as is", and it does not address the circumstances of any particular individual or entity. Nothing herein constitutes professional advice, nor does it constitute a comprehensive or complete statement of the issues discussed thereto. ASCENT does not warrant that the document or information will be error free or will meet any particular criteria of performance or quality. In particular (but without limitation) information may be rendered inaccurate by changes made to the subject of the materials (i.e. applicable software). Rand Worldwide, Inc. specifically disclaims any warranty, either expressed or implied, including the warranty of fitness for a particular purpose.



# Contents

<b>Preface</b> .....	<b>ix</b>
<b>In This Guide</b> .....	<b>xi</b>
<b>Practice Files</b> .....	<b>xiii</b>
<b>Chapter 1: 3D Foundations</b> .....	<b>1-1</b>
<b>1.1 Why Use 3D?</b> .....	<b>1-2</b>
Types of 3D Models .....	1-2
<b>1.2 Introduction to the 3D Modeling Workspace</b> .....	<b>1-4</b>
3D Ribbon Panels .....	1-5
<b>1.3 Basic 3D Viewing Tools</b> .....	<b>1-8</b>
Preset 3D Views.....	1-8
Orbiting in 3D .....	1-10
Using Visual Styles .....	1-12
<b>1.4 3D Navigation Tools</b> .....	<b>1-13</b>
ViewCube.....	1-13
SteeringWheel.....	1-16
<b>Practice 1a 3D Navigation Tools</b> .....	<b>1-19</b>
<b>1.5 Introduction to the User Coordinate System (UCS)</b> .....	<b>1-23</b>
Dynamic UCS.....	1-24
<b>Practice 1b Introduction to the User Coordinate System</b> .....	<b>1-26</b>
<b>Chapter Review Questions</b> .....	<b>1-28</b>
<b>Command Summary</b> .....	<b>1-30</b>
<b>Chapter 2: Simple Solids</b> .....	<b>2-1</b>
<b>2.1 Working with Solid Primitives</b> .....	<b>2-2</b>
Drawing Solid Primitives .....	2-2
Editing Solid Primitives.....	2-3

---

<b>2.2 Solid Primitive Types</b> .....	<b>2-5</b>
Creating Boxes and Wedges .....	2-5
Creating Pyramids.....	2-7
Creating Cylinders and Cones .....	2-9
Creating Spheres and Tori .....	2-11
Creating Wall-like Solids with Polysolid .....	2-13
<b>Practice 2a Working with Solid Primitives - Architectural</b> .....	<b>2-15</b>
<b>Practice 2b Working with Solid Primitives - Mechanical</b> .....	<b>2-16</b>
<b>2.3 Working with Composite Solids</b> .....	<b>2-18</b>
Creating Composite Solids.....	2-18
Modifying Composite Solids.....	2-21
<b>Practice 2c Working with Composite Solids</b> .....	<b>2-23</b>
<b>Practice 2d Mechanical Project - Machine Part</b> .....	<b>2-24</b>
<b>Practice 2e Architectural Project - Facade Puzzle</b> .....	<b>2-27</b>
<b>2.4 Working with Mesh Models</b> .....	<b>2-30</b>
Creating Mesh Primitives .....	2-30
Creating Mesh Models from Objects.....	2-32
Editing Mesh Models.....	2-33
Convert From Mesh Models.....	2-38
<b>Practice 2f Mesh Model</b> .....	<b>2-39</b>
<b>Chapter Review Questions</b> .....	<b>2-43</b>
<b>Command Summary</b> .....	<b>2-45</b>
<b>Chapter 3: Working with the User Coordinate System</b> .....	<b>3-1</b>
<b>3.1 UCS Basics</b> .....	<b>3-2</b>
UCS Icon.....	3-3
Moving the UCS Origin .....	3-5
Moving the UCS to a Face .....	3-6
Moving the UCS Using 3 Points.....	3-6
<b>Practice 3a Using the UCS</b> .....	<b>3-8</b>
<b>3.2 UCS X, Y, and Z Commands</b> .....	<b>3-11</b>
<b>Practice 3b X, Y, and Z Commands</b> .....	<b>3-13</b>
<b>3.3 UCS Multi-functional Grips</b> .....	<b>3-17</b>
<b>3.4 Saving a UCS by Name</b> .....	<b>3-18</b>
<b>Practice 3c Working with Named UCSs</b> .....	<b>3-21</b>
<b>Chapter Review Questions</b> .....	<b>3-22</b>
<b>Command Summary</b> .....	<b>3-24</b>

<b>Chapter 4: Creating Solids and Surfaces from 2D Objects .....</b>	<b>4-1</b>
<b>4.1 Complex 3D Geometry.....</b>	<b>4-2</b>
Creating Surfaces and Solids.....	4-2
<b>4.2 Extruded Solids and Surfaces .....</b>	<b>4-3</b>
Presspull .....	4-4
Modifying Extrusions .....	4-6
<b>Practice 4a Creating an Extruded Solid .....</b>	<b>4-7</b>
<b>Practice 4b Extruding Along a Path .....</b>	<b>4-9</b>
<b>4.3 Swept Solids and Surfaces .....</b>	<b>4-10</b>
Modifying Sweeps .....	4-11
3D Paths .....	4-12
<b>Practice 4c Creating a Swept Solid .....</b>	<b>4-14</b>
<b>Practice 4d Sweeping Along a Helix.....</b>	<b>4-16</b>
<b>Practice 4e Sweeping Along a 3D Polyline.....</b>	<b>4-18</b>
<b>4.4 Revolved Solids and Surfaces.....</b>	<b>4-20</b>
Modifying Revolves .....	4-21
<b>Practice 4f Creating Revolved Solids.....</b>	<b>4-22</b>
<b>4.5 Lofted Solids and Surfaces.....</b>	<b>4-24</b>
Modifying Lofts .....	4-27
<b>Practice 4g Creating a Lofted Solid.....</b>	<b>4-28</b>
<b>Practice 4h Basic Solid and Surface Editing.....</b>	<b>4-29</b>
<b>4.6 NURBS Surfaces .....</b>	<b>4-31</b>
Creating NURBS Surfaces.....	4-31
Edit NURBS Surfaces .....	4-32
<b>Practice 4i Create and Edit a NURBS Surface.....</b>	<b>4-39</b>
<b>Chapter Review Questions.....</b>	<b>4-43</b>
<b>Command Summary .....</b>	<b>4-45</b>
<b>Chapter 5: Modifying in 3D Space.....</b>	<b>5-1</b>
<b>5.1 3D Gizmo Tools .....</b>	<b>5-2</b>
<b>Practice 5a 3D Gizmo Tools .....</b>	<b>5-5</b>
<b>5.2 Aligning Objects in 3D Space .....</b>	<b>5-8</b>
Align Command.....	5-8
3D Align Command.....	5-10
<b>Practice 5b Aligning Objects in 3D.....</b>	<b>5-12</b>

---

<b>5.3 3D Modify Commands</b> .....	<b>5-14</b>
3D Move and 3D Rotate.....	5-14
3D Scale.....	5-15
Mirroring Objects in 3D .....	5-15
Arraying Objects in 3D .....	5-16
<b>Practice 5c Working with 3D Modify Commands</b> .....	<b>5-18</b>
<b>Practice 5d Architectural Project - Gallery</b> .....	<b>5-20</b>
<b>Chapter Review Questions</b> .....	<b>5-22</b>
<b>Command Summary</b> .....	<b>5-24</b>
<b>Chapter 6: Advanced Solid Editing</b> .....	<b>6-1</b>
<b>6.1 Editing Components of Solids</b> .....	<b>6-2</b>
Editing Faces .....	6-5
Editing Edges .....	6-5
Editing Vertices .....	6-6
Modification Options.....	6-6
<b>Practice 6a Editing Components of Solids</b> .....	<b>6-7</b>
<b>6.2 Editing Faces of Solids</b> .....	<b>6-10</b>
Extruding Faces .....	6-11
Offsetting Faces and Edges.....	6-12
Moving Faces.....	6-14
Rotating Faces.....	6-15
Tapering Faces .....	6-16
Removing Faces .....	6-17
Copying Faces .....	6-18
<b>Practice 6b Editing Faces of Solids</b> .....	<b>6-19</b>
<b>6.3 Fillets and Chamfers on Solids</b> .....	<b>6-22</b>
<b>Practice 6c Fillets and Chamfers on Solids</b> .....	<b>6-25</b>
<b>Practice 6d Mechanical Project: Bracket</b> .....	<b>6-28</b>
<b>Chapter Review Questions</b> .....	<b>6-29</b>
<b>Command Summary</b> .....	<b>6-30</b>
<b>Chapter 7: Additional Editing Tools</b> .....	<b>7-1</b>
<b>7.1 Creating a Shell</b> .....	<b>7-2</b>
<b>Practice 7a Creating a Shell</b> .....	<b>7-3</b>
<b>7.2 Imprinting Edges of Solids</b> .....	<b>7-5</b>
<b>Practice 7b Imprinting Edges on a Solid</b> .....	<b>7-7</b>
<b>7.3 Slicing a Solid Along a Plane</b> .....	<b>7-9</b>
<b>Practice 7c Slicing a Solid</b> .....	<b>7-11</b>

<b>7.4 Interference Checking .....</b>	<b>7-13</b>
<b>Practice 7d Interference Checking .....</b>	<b>7-17</b>
<b>7.5 Converting Objects to Surfaces .....</b>	<b>7-19</b>
Creating Planar Surfaces from 2D Objects .....	7-19
Converting 2D Objects to Surfaces .....	7-20
Converting Solids to Surfaces .....	7-21
<b>7.6 Converting Objects to Solids .....</b>	<b>7-22</b>
Converting 2D Objects to Solids .....	7-22
Converting Surfaces to Solids .....	7-23
Converting Solids or Surfaces to Wireframe .....	7-24
<b>Practice 7e Converting Objects to Surfaces and Solids .....</b>	<b>7-25</b>
<b>Practice 7f Mechanical Project - Connector .....</b>	<b>7-29</b>
<b>Chapter Review Questions .....</b>	<b>7-30</b>
<b>Command Summary .....</b>	<b>7-31</b>
<b>Chapter 8: Refining the View .....</b>	<b>8-1</b>
<b>8.1 Working with Sections .....</b>	<b>8-2</b>
Working With Sections .....	8-2
Setting the Section Plane .....	8-3
Working with Live Sections .....	8-5
Generating Sections from Section Planes .....	8-7
<b>Practice 8a Working with Sections .....</b>	<b>8-9</b>
<b>8.2 Working with Cameras .....</b>	<b>8-11</b>
Adjusting a Camera .....	8-13
Clipping Camera Views .....	8-14
<b>Practice 8b Working with Cameras .....</b>	<b>8-16</b>
<b>8.3 Managing Views in 3D .....</b>	<b>8-19</b>
Modifying Views .....	8-23
<b>Practice 8c Managing Views in 3D .....</b>	<b>8-25</b>
<b>8.4 Animating with ShowMotion .....</b>	<b>8-29</b>
<b>8.5 Creating ShowMotion Shots .....</b>	<b>8-31</b>
<b>Practice 8d Animating with ShowMotion .....</b>	<b>8-34</b>
<b>8.6 Creating Animations .....</b>	<b>8-37</b>
Using Walk and Fly .....	8-38
Animating a Walkthrough .....	8-41
Animation Motion Paths .....	8-43
<b>Practice 8e Walking and Flying Through Models .....</b>	<b>8-45</b>
<b>Chapter Review Questions .....</b>	<b>8-47</b>
<b>Command Summary .....</b>	<b>8-49</b>

---

<b>Chapter 9: Point Clouds</b> .....	<b>9-1</b>
<b>9.1 Point Clouds</b> .....	<b>9-2</b>
Attach Point Cloud .....	9-2
Point Cloud Contextual Tab .....	9-4
Object Snap .....	9-13
Dynamic UCS.....	9-14
<b>Practice 9a Attach a Point Cloud</b> .....	<b>9-15</b>
<b>Practice 9b Working with Sections</b> .....	<b>9-17</b>
<b>Chapter Review Questions</b> .....	<b>9-22</b>
<b>Command Summary</b> .....	<b>9-23</b>
<b>Chapter 10: Visualization</b> .....	<b>10-1</b>
<b>10.1 Creating Visual Styles</b> .....	<b>10-2</b>
Visual Style Settings .....	10-4
<b>Practice 10a Creating Visual Styles</b> .....	<b>10-11</b>
<b>10.2 Working with Materials</b> .....	<b>10-13</b>
Using the Materials Browser .....	10-14
Libraries .....	10-15
Adding Materials .....	10-17
Attaching Materials by Layer.....	10-20
Material Editor.....	10-21
Texture Editor.....	10-24
<b>Practice 10b Working with Materials</b> .....	<b>10-25</b>
<b>10.3 Specifying Light Sources</b> .....	<b>10-30</b>
Default Lighting .....	10-30
Sunlight .....	10-31
User-Defined Lights .....	10-37
Modifying Lights .....	10-41
<b>Practice 10c Creating a Sun Study</b> .....	<b>10-43</b>
<b>Practice 10d Placing Lights in a Model</b> .....	<b>10-46</b>
<b>10.4 Rendering Concepts</b> .....	<b>10-49</b>
Adjusting the Exposure .....	10-52
Render Presets Manager.....	10-53
<b>Practice 10e Rendering Concepts</b> .....	<b>10-55</b>
<b>Chapter Review Questions</b> .....	<b>10-58</b>
<b>Command Summary</b> .....	<b>10-60</b>



---

<b>Chapter 11: Working Drawings from 3D Models .....</b>	<b>11-1</b>
<b>11.1 Creating Multiple Viewports.....</b>	<b>11-2</b>
<b>Practice 11a Creating Multiple Viewports .....</b>	<b>11-5</b>
<b>11.2 2D Views from 3D Solids .....</b>	<b>11-8</b>
Creating Hidden Line Views.....	11-9
Creating Profiles from Solids.....	11-11
<b>Practice 11b 2D Views from 3D Solids .....</b>	<b>11-13</b>
<b>11.3 Creating Technical Drawings with Flatshot.....</b>	<b>11-17</b>
<b>Practice 11c Creating Technical Drawings with Flatshot.....</b>	<b>11-20</b>
<b>Practice 11d Mechanical Project - Saddle.....</b>	<b>11-22</b>
<b>11.4 3D Model Import .....</b>	<b>11-23</b>
<b>11.5 Automatic Model Documentation .....</b>	<b>11-24</b>
Adding Base Views .....	11-26
Adding Projected Views .....	11-28
Editing Drawing Views .....	11-31
<b>Practice 11e Creating Automatic Model Documentation.....</b>	<b>11-33</b>
<b>11.6 3D Printing .....</b>	<b>11-38</b>
3D Print Service .....	11-38
<b>Practice 11f Send a 3D Model to Print.....</b>	<b>11-39</b>
<b>Chapter Review Questions.....</b>	<b>11-41</b>
<b>Command Summary .....</b>	<b>11-43</b>
<b>Appendix A: Skills Assessment.....</b>	<b>A-1</b>
<b>Index .....</b>	<b>Index-1</b>



# Preface

The *AutoCAD® 2023: 3D Drawing and Modeling* guide is designed for those using AutoCAD® 2023 with a Windows operating system. This guide is not designed for the AutoCAD for Mac software.

The *AutoCAD 2023: 3D Drawing and Modeling* guide introduces users, who are proficient with the 2D commands in the AutoCAD software, to the concepts and methods of 3D modeling. The guide provides a thorough grounding in the fundamentals of 3D and explores the main features of the advanced 3D Modeling workspace in the AutoCAD software.

## Topics Covered

- 3D viewing techniques
- Working with simple and composite solids
- Creating complex solids and surfaces
- Modifying objects in 3D space
- Editing solids
- Creating sections, camera perspectives, and animations
- Working with point clouds
- Converting 3D objects
- Setting up a rendering with materials and lights
- Creating 2D drawings from 3D models
- Working with the User Coordinate System
- Set up a drawing for 3D Prints

## Prerequisites

- Access to the 2023.0 version of the software, to ensure compatibility with this guide. Future software updates that are released by Autodesk may include changes that are not reflected in this guide. The practices and files included with this guide might not be compatible with prior versions (e.g., 2022).
- A good working skill level in the AutoCAD software, i.e., a minimum of 80 hours of work experience with the AutoCAD software, is recommended.

## Note on Software Setup

This guide assumes a standard installation of the software using the default preferences during installation. Lectures and practices use the standard software templates and default options for the Content Libraries.

## Lead Contributor: Renu Muthoo

Renu uses her instructional design training to develop courseware for AutoCAD and AutoCAD vertical products, Autodesk 3ds Max, Autodesk Showcase and various other Autodesk software products. She has worked with Autodesk products for the past 20 years with a main focus on design visualization software.

Renu holds a bachelor's degree in Computer Engineering and started her career as a Instructional Designer/Author where she co-authored a number of Autodesk 3ds Max and AutoCAD books, some of which were translated into other languages for a wide audience reach. In her next role as a Technical Specialist at a 3D visualization company, Renu used 3ds Max in real-world scenarios on a daily basis. There, she developed customized 3D web planner solutions to create specialized 3D models with photorealistic texturing and lighting to produce high quality renderings.

Renu Muthoo has been the Lead Contributor for *AutoCAD: 3D Drawing and Modeling* since 2019.



# In This Guide

The following highlights the key features of this guide.

Feature	Description
<b>Practice Files</b>	The Practice Files page includes a link to the practice files and instructions on how to download and install them. The practice files are required to complete the practices in this guide.
<b>Chapters</b>	<p>A chapter consists of the following - Learning Objectives, Instructional Content, Practices, Chapter Review Questions, and Command Summary.</p> <ul style="list-style-type: none"><li>• <b>Learning Objectives</b> define the skills you can acquire by learning the content provided in the chapter.</li><li>• <b>Instructional Content</b>, which begins right after Learning Objectives, refers to the descriptive and procedural information related to various topics. Each main topic introduces a product feature, discusses various aspects of that feature, and provides step-by-step procedures on how to use that feature. Where relevant, examples, figures, helpful hints, and notes are provided.</li><li>• <b>Practice</b> for a topic follows the instructional content. Practices enable you to use the software to perform a hands-on review of a topic. It is required that you download the practice files (using the link found on the Practice Files page) prior to starting the first practice.</li><li>• <b>Chapter Review Questions</b>, located close to the end of a chapter, enable you to test your knowledge of the key concepts discussed in the chapter.</li><li>• <b>Command Summary</b> concludes a chapter. It contains a list of the software commands that are used throughout the chapter and provides information on where the command can be found in the software.</li></ul>
<b>Appendices</b>	Appendices provide additional information to the main course content. It could be in the form of instructional content, practices, tables, projects, or skills assessment.

## 3D Foundations

In this chapter, you learn how to identify 3D models, use the 3D workspace, view a 3D model from different angles, shade the model using visual styles, and understand the user coordinate system (UCS).

### Learning Objectives in This Chapter

---

- Describe the differences between 2D drawings and 3D models.
- Access the 3D drawing and viewing tools using the ribbon through 3D-specific workspaces.
- View objects from all directions using preset 3D views and 3D orbiting tools.
- Control how elements display in a view using the visual styles.
- Navigate 3D drawings with additional tools, including the ViewCube and the SteeringWheel.
- Move the UCS to a face on a 3D object using the Dynamic UCS.

## 1.1 Why Use 3D?

2D plans and schematics are diagrams that represent an object by reducing it to a simpler form. For example, two parallel lines are easily recognized as the symbol for a wall, although they are not actually a wall. However, a 3D model is a complete object in all its dimensions. A complete 3D model of a wall can include all interior framing, the drywall, the baseboards, etc. At the very least, it would display the height, length, and width of the wall.

Likewise, a three-view 2D mechanical drawing is a symbolic representation of an object from various directions. If you want to view the object from another angle, you must draw another 2D view. However, a 3D mechanical model is a single object that can be viewed from many directions, as shown in Figure 1–1.

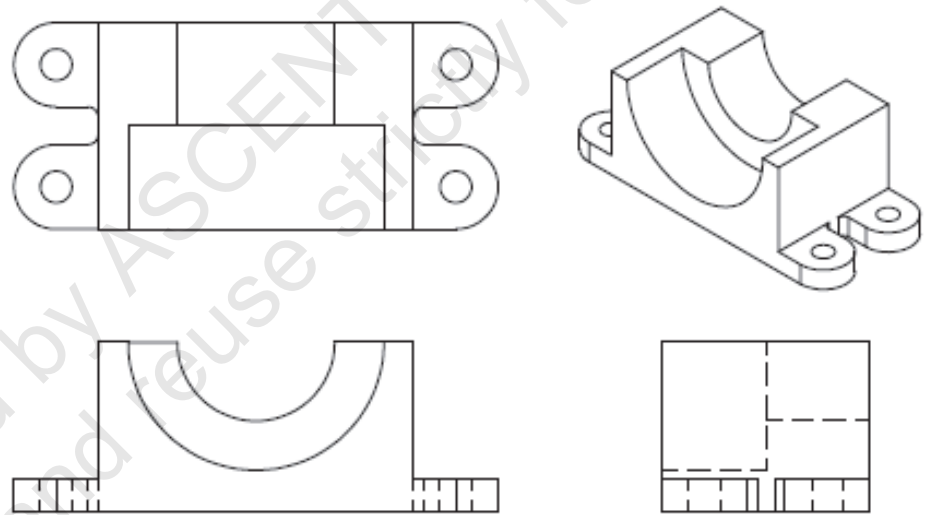

Figure 1–1

A 3D model:

- Can be viewed from any direction.
- Can be used to generate 2D views as required.
- Can be rendered to create photo-realistic images of the finished model.

### Types of 3D Models

You can create four types of 3D models with the AutoCAD® software: wireframe, surface, mesh, and solid, as shown in Figure 1–2.

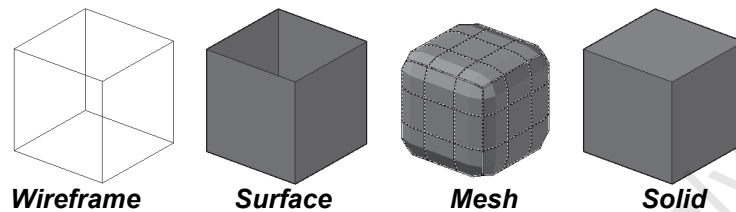

Figure 1-2

**Wireframe models:** Represent the 3D object by indicating its edges. There are no surfaces between the edges. Therefore, you can see through the object. For example, you can use a wireframe drawing to display a plumbing riser diagram. You can also use wireframe objects as paths or frameworks for other 3D objects.

**Surface models:** Consist of infinitely thin surfaces that represent the *shell* of an object. Since the surfaces are opaque, the edges behind them can be hidden. However, the model cannot be used for mechanical or thermal analysis because the thin surfaces do not have a mass. You can use surfaces to create contour maps or other complex geometry, such as a car body or cell phone design. You can also use surfaces to cut solids and apply complex geometry to them.

**Mesh models:** Consist of polygons that form edges, faces, and vertices. They do not have mass and can be used to create complex shapes that can be created, split, and deformed as required. They can be shaded and rendered without having a mass and can be a useful alternative to solids.

**Solid models:** Can look like surface models, but are solid blocks of material, rather than hollow. A solid model has mass and can be used for mechanical and thermal analysis, and renderings. Solids can be used to create anything from a doorknob, to a large machine, or to a massing study for a new high-rise.

#### Hint: Advanced 3D Modeling

The 3D tools in the AutoCAD software are primarily for conceptual design, but can be used to create objects and then to create working drawings from them. Autodesk supplies *vertical* software, such as Autodesk® Inventor® for mechanical design, Autodesk® Revit® Architecture for architectural design, and Autodesk® Civil 3D® and Autodesk® InfraWorks® for civil design, each of which are more powerful in their specific disciplines. For advanced rendering and animations, you would use the Autodesk® 3ds Max® software.

# 1.2 Introduction to the 3D Modeling Workspace

When you are ready to begin working in 3D, you need special tools and visual clues to help you move from the flat 2D world into the full-featured world of the third dimension. The AutoCAD software includes a 3D modeling workspace with easy access to 3D drawing and viewing tools, as shown in Figure 1–3.

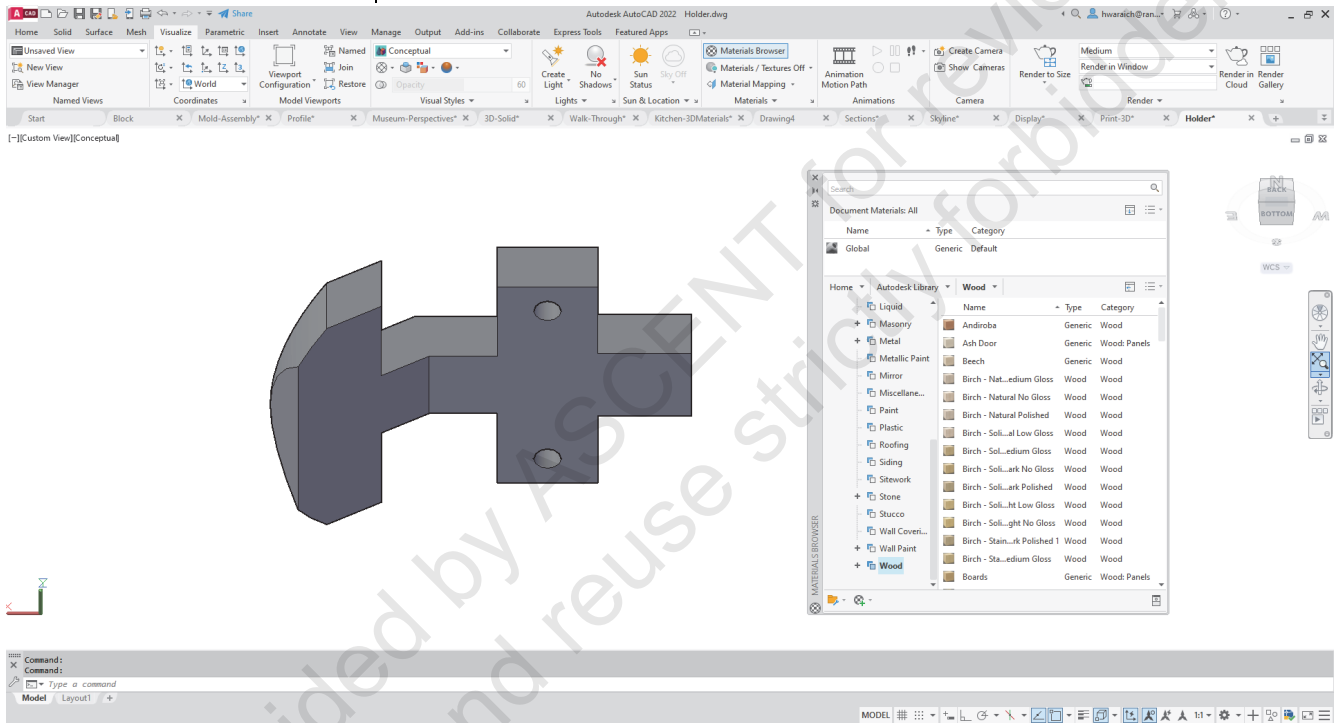

Figure 1–3

- The 3D Modeling workspace might not be available and is required to be turned on. You can open the 3D Modeling workspace by selecting **3D Modeling** in the Status Bar, as shown in Figure 1–4.

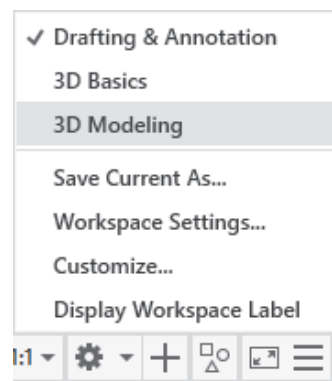

Figure 1–4



To display the Workspace list in the Quick Access Toolbar, toggle on **Workspace** in the  (Customize Toolbar).

## 3D Ribbon Panels

- You can also open the 3D Modeling workspace in the Quick Access Toolbar by selecting **3D Modeling** in the Workspace drop-down list.
- You can also use the 3D Basics workspace, which contains many commonly used commands.
- Use the ribbon tabs and panels to access the 3D tools.
- Toggle the Tool Palettes off or set them to **Auto-Hide** to save space in the drawing window. They are primarily used for lights and other visualization commands.

The 3D Modeling workspace includes ribbon tabs and panels that contain commonly used 3D tools. The tabs are: *Home, Solid, Surface, Mesh, Visualize, Parametric, Insert, Annotate, View, Manage, Output, Add-ins, Collaborate, Express Tools, and Featured Apps tabs.*

- The 3D Basics workspace contains the *Home, Visualize, Insert, View, Manage, Output, Add-ins, Collaborate, Express Tools, and Featured Apps tabs.*

The *Home* tab of the 3D Modeling workspace includes the following panels: Modeling, Mesh, Solid Editing, Draw, Modify, Section, Coordinates, View, Selection, Layers, Groups, and View, as shown in Figure 1–5.

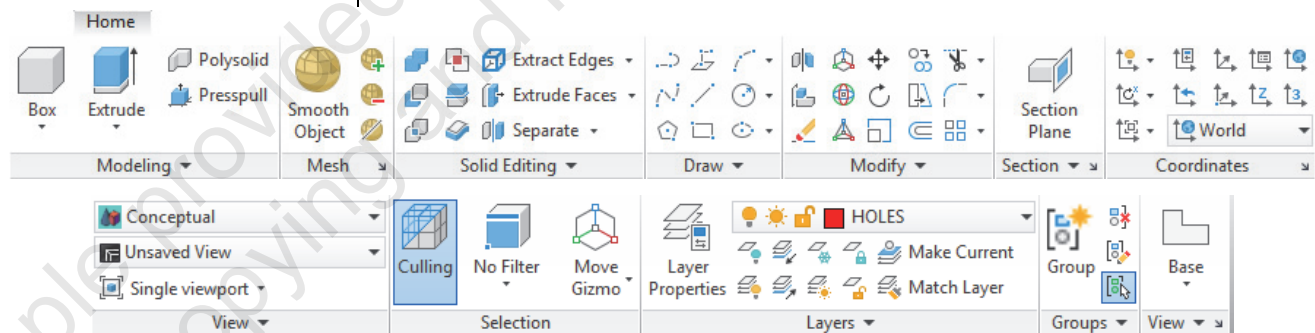

Figure 1–5

The *Solid* tab includes the following panels: Primitives, Solid, Boolean, Solid Editing, Section, and Selection, as shown in Figure 1–6.

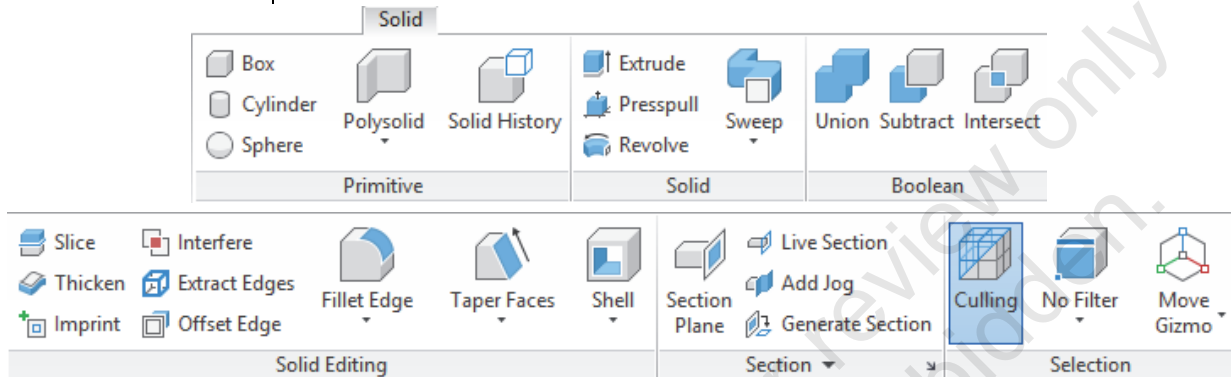

Figure 1–6

The *Surface* tab includes the following panels: Create, Edit, Control Vertices, Curves, Project Geometry, and Analysis, as shown in Figure 1–7.

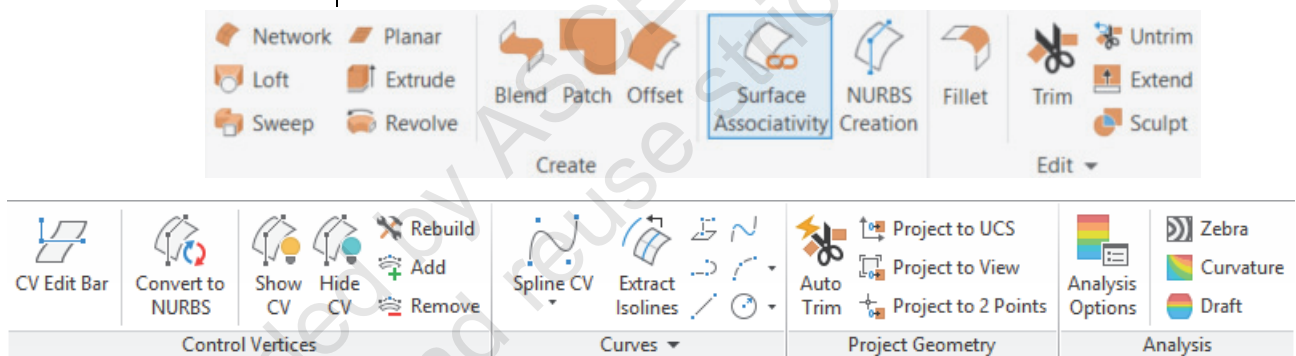

Figure 1–7

The *Mesh* tab includes the following panels: Primitives, Mesh, Mesh Edit, Convert Mesh, Section, and Selection, as shown in Figure 1–8.

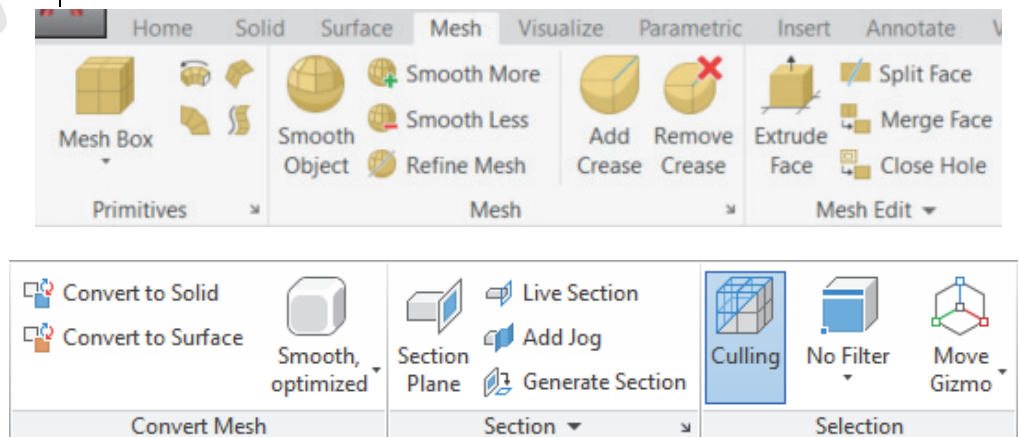
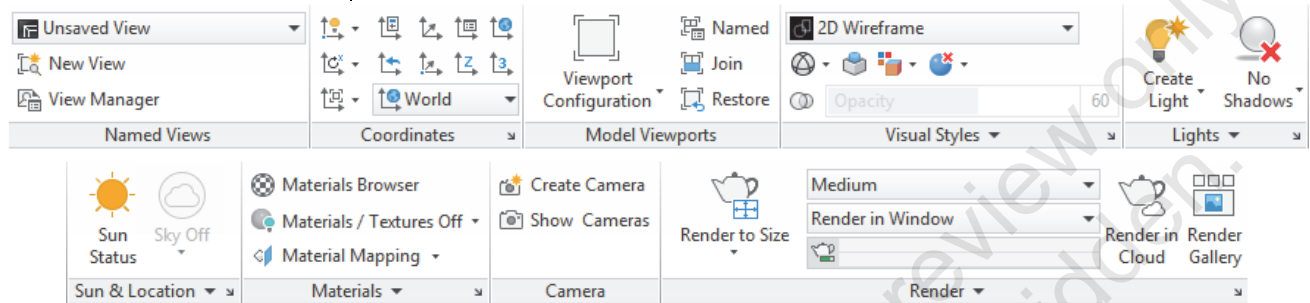

Figure 1–8

The *Visualize* tab includes the following panels: Named Views, Coordinates, Model Viewports, Visual Styles, Lights, Sun & Location, Materials, Camera, and Render, as shown in Figure 1–9.



**Figure 1–9**

The *View* tab includes the following panels: Viewport Tools, Named Views, Palettes, and Interface, as shown in Figure 1–10.

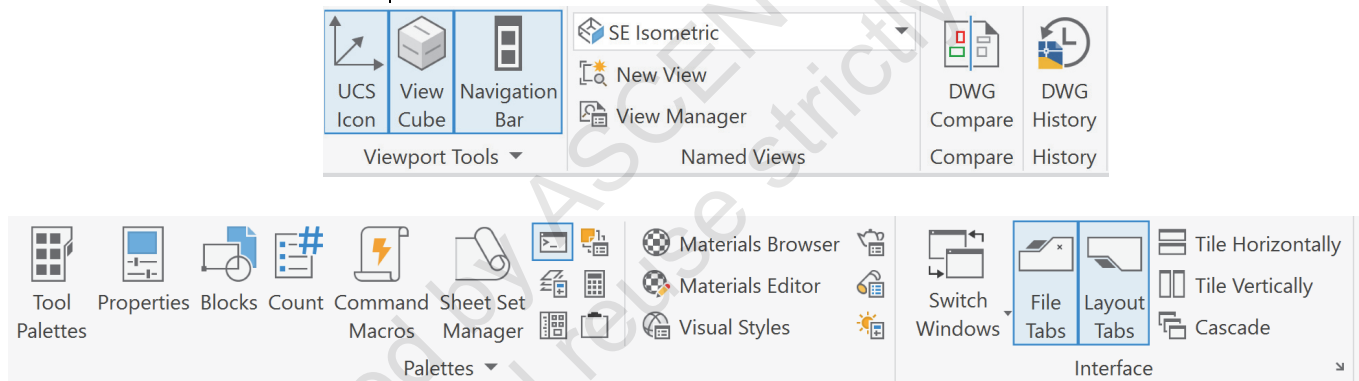

**Figure 1–10**

## 1.3 Basic 3D Viewing Tools

As you are working in 3D, you need to be able to view objects from all directions. There are several basic tools that enable you to do so: preset 3D views, orbiting, and Visual Styles.

### Preset 3D Views

The AutoCAD software provides a number of standard preset 3D views (orthographic and isometric) that enable you to quickly change the viewing angle. They are located in the *Home* tab > View panel or in the **View Controls** label of the drawing window, as shown in Figure 1–11.

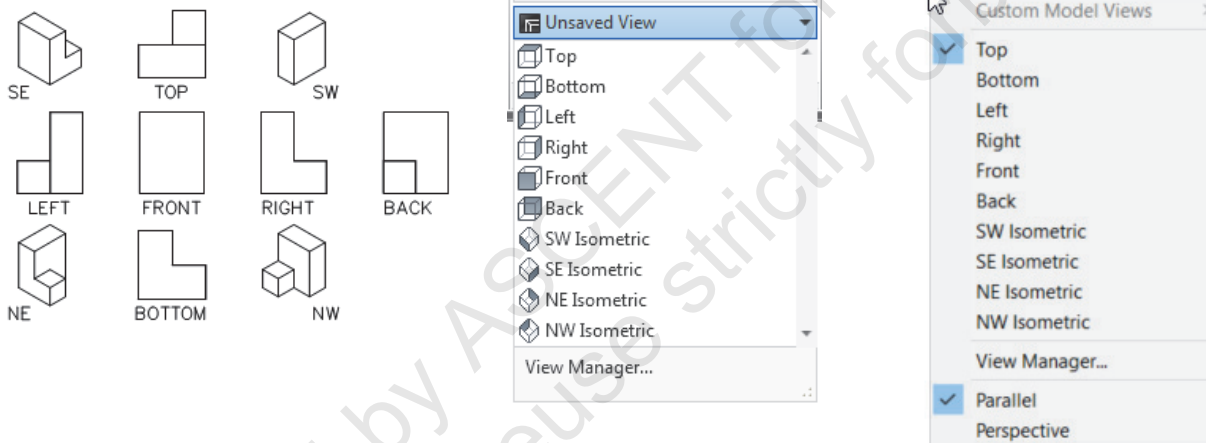

*Home* tab > View panel    Drawing window > View Controls label

Figure 1–11

Orthographic views display as if you are facing directly onto one side of a part. Isometric views typically display three sides, as if you are facing a corner. For example, an orthographic view of the cube would display one face: a square. An isometric view might display the top, left, and front sides of the cube.

- Orthographic views change the active drawing plane (UCS) of the view. This means that you can draw on that plane without having to manually change the UCS.
- Isometric views do not change the active drawing plane (UCS). To return to the flat drawing plane, select the **Top** view before continuing with a non-orthographic 3D view.

## Drawing Window Setup

When you are new to working in 3D, you might find it helpful to setup your drawing window so that you can see the model you are working on from multiple viewing angles at the same time. For instance, you might want to view the model from the top view, a side view, and the front view all at once, while also viewing it in 3D, as shown in Figure 1–12.

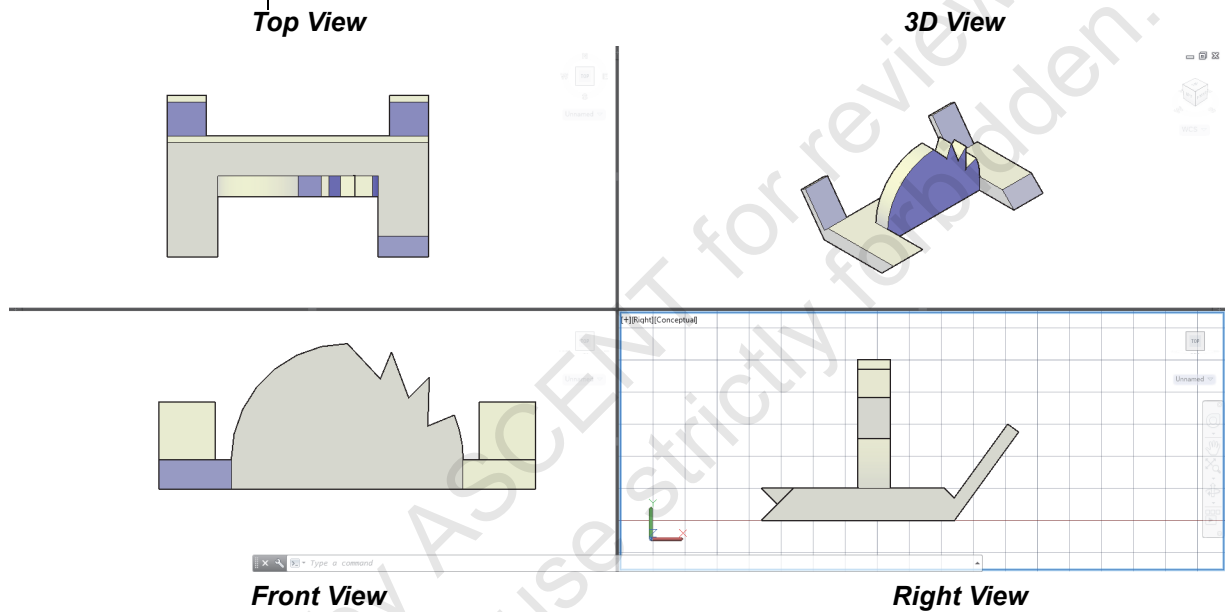

Figure 1–12

## How To: Set Up the Drawing Window for Multiple Viewing Angles

1. In the *Visualize* tab>Model Viewports panel, expand



(Viewports Configuration) and select the desired configuration, as shown in Figure 1–13.

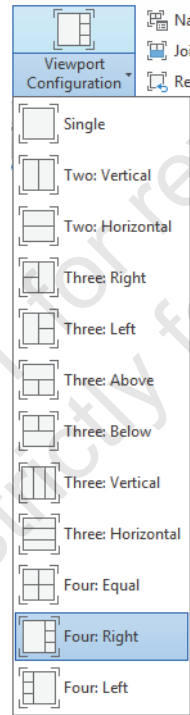
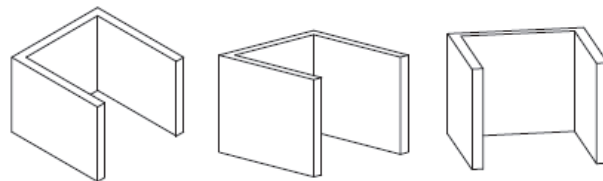

**Figure 1–13**

2. Click inside a viewport and change the viewing angle as required.
3. Click inside each of the other viewports and change their viewing angle so that each one is different.

## Orbiting in 3D

The best tools for viewing in 3D are the mouse and keyboard. You can zoom in and out using the mouse’s scroll wheel and can pan by holding the scroll wheel and dragging the mouse. Both methods are useful in 2D and 3D. However, in 3D you also need to view the model from all sides. Hold <Shift> and the scroll wheel of the mouse to temporarily orbit the objects in your drawing, as shown in Figure 1–14.



**Figure 1–14**

- When you orbit, the target (what you are viewing) stays stationary while the camera (your viewpoint) moves.
- You can also hold <Ctrl> and the scroll wheel to temporarily swivel. This is similar to panning the camera as you drag the mouse. The target of the view changes.
- If you select objects before you start orbiting, only those objects display as you move around the drawing. This is useful in complex drawings, because limiting the number of objects results in a smoother rotation of the view.

### Additional Orbiting Commands

Additional orbiting commands are available in the *View* tab > *Navigate* panel and in the *Navigation Bar*, as shown in Figure 1–15.

*If the **Navigate** panel is not visible, right-click in the ribbon area and select **Show Panels > Navigate**.*

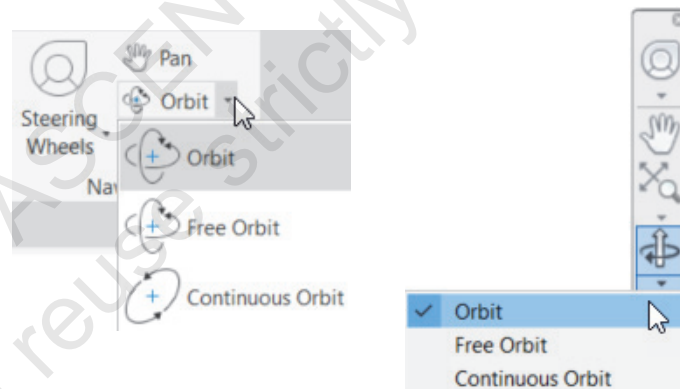

**Figure 1–15**



**Orbit:** Orbits along the XY plane or Z-axis.



**Free Orbit:** Orbits without any constraint to a plane or axis. A green circle called an arc ball displays. When you move the cursor over different parts of the arc ball, the view moves in different directions.



**Continuous Orbit:** Rotates the viewpoint at a constant speed until you stop the rotation. Gives the impression of spinning the object in 3D space. To start the rotation, hold the mouse button, move the cursor, and release the button. The speed at which you move the cursor determines the speed of rotation, and the direction in which you move the cursor determines the direction of rotation.

- Use the mouse button rather than the scroll wheel to move around the drawing.
- When you are in a command, right-click to change between the various 3D viewing commands.

## Using Visual Styles

While viewing a model, setting a visual style can help you gain a clearer understanding of the model. Visual styles control how elements display in a view. They might display all edges of the objects at the same time or just the ones closest to the viewer. Materials associated with the objects might be displayed or only shaded surfaces. You can add and modify objects and orbit in any of the visual styles.

Many preset visual styles come with the AutoCAD software, such as: 2D Wireframe, Conceptual, Realistic, Shaded, Shades of Gray, etc. Select a Visual Style by expanding Realistic in the *Home* tab>View panel and then selecting an option, as shown on the left in Figure 1–16. Some of the visual styles are also available in the Visual Style Controls label in the drawing window, as shown on the right in Figure 1–16.

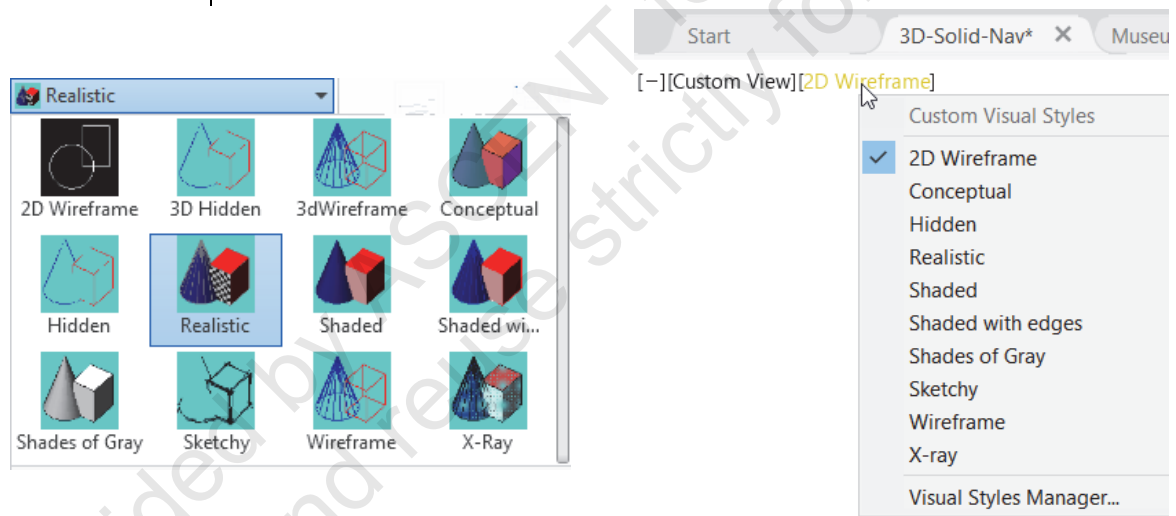

**Figure 1–16**

- If you are working in an orthographic view, set the *visual style* to **2D Wireframe** for the best results.
- In Paper Space, you must be in an active Model Space viewport before applying a visual style.



## 1.4 3D Navigation Tools

The AutoCAD software includes two additional tools to help you navigate 3D drawings: the ViewCube and the SteeringWheel (located in the Navigation Bar), as shown in Figure 1–17.

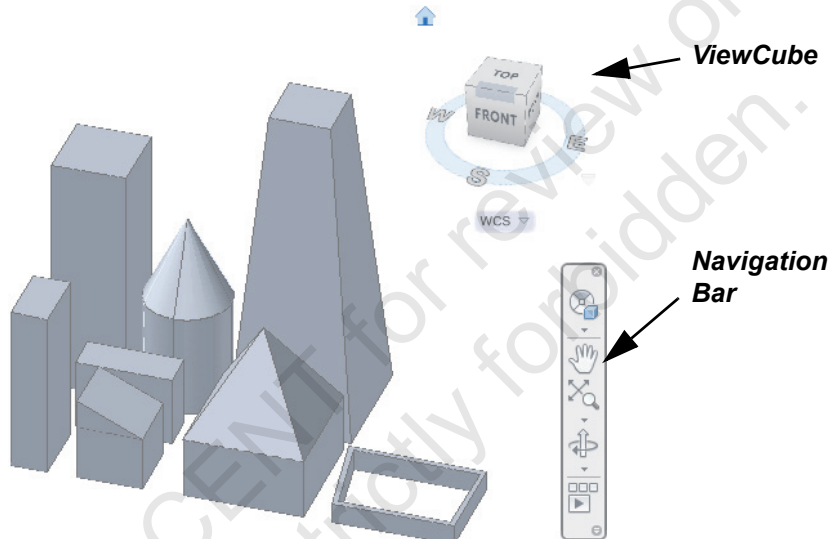

Figure 1–17

### ViewCube

The ViewCube provides visual clues as to where you are in a 3D drawing and makes it easier to navigate to standard views, such as top, front, right, corner and directional views. Move the cursor over one of the highlighted options and select it. You can also click and drag on the ViewCube to rotate the box, which rotates the model. The ViewCube is shown in Figure 1–18.

*To change the Home view, set the view you want, right-click on the ViewCube, and select **Set Current View as Home**.*

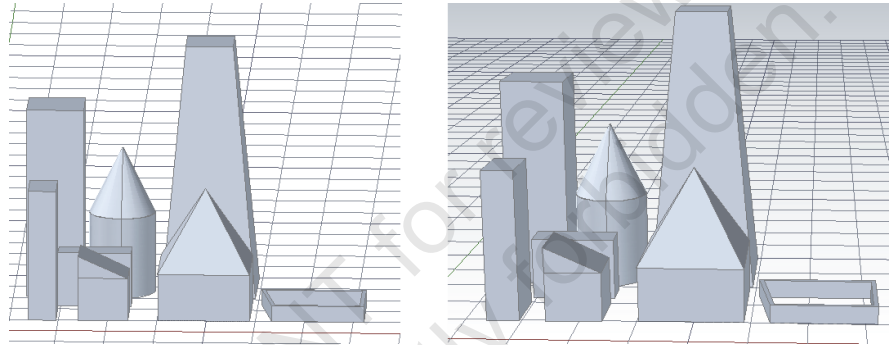

Figure 1–18

-  (Home) displays when you move the cursor over the ViewCube. Click it to return to the view defined as **Home**.
- To toggle the ViewCube on and off, in the *View* tab>ViewPort Tools panel, select **ViewCube**.

**Hint: Parallel and Perspective Views**

Traditional 2D drawings display objects in orthographic (parallel) views, where parallel edges on the object seem to be parallel in the drawing. Perspective views display as the eye sees and parallel edges seem to converge at a vanishing point on the horizon. You can view the model in either Parallel or Perspective projection, as shown in Figure 1–19.

**Figure 1–19**

A parallel view helps you to evaluate the object's shape and size proportions without any distortion, while a perspective view gives you a better sense of space and depth, especially with large objects (such as buildings).

- You can draw, select, and modify objects while you are in a perspective view.
- You can switch between **Parallel**, **Perspective**, and **Perspective with Ortho Faces** when you right-click on the ViewCube or while you are in a **3D Orbit** command.
- You can also switch between **Parallel** and **Perspective** in the **View Controls** label list of the drawing window.
- Perspective mode is not available in the 2D wireframe visual style.
- If you save a drawing as a version earlier than the AutoCAD 2007 software, the Perspective view is automatically toggled off.

## ViewCube Settings

ViewCube settings control the display of the ViewCube, how it works when you are dragging or clicking, and several other settings. Right-click on the ViewCube and select **ViewCube Settings...** to open the ViewCube Settings dialog box, as shown in Figure 1–20.

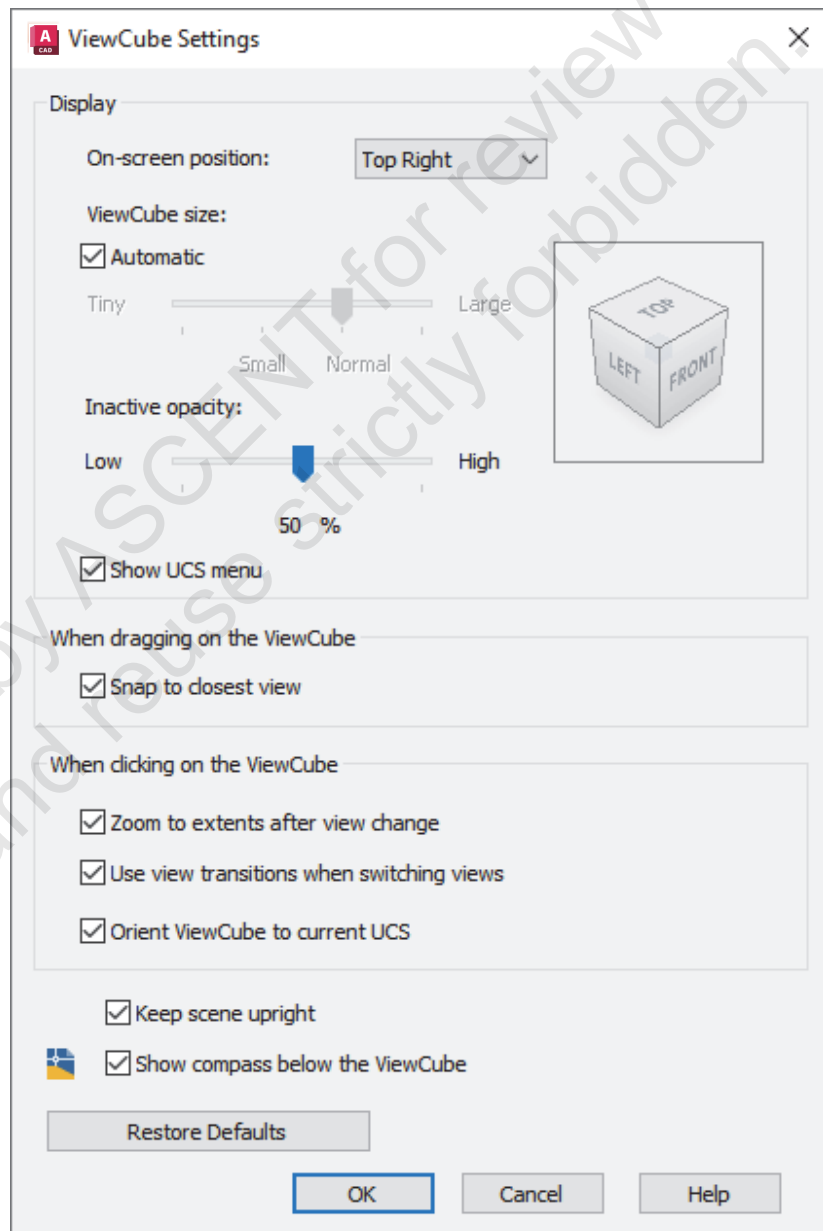



Figure 1–20

## SteeringWheel

The SteeringWheel provides access to navigation commands such as **Zoom**, **Pan**, **Orbit**, and **Rewind**. The **Rewind** command navigates through all previous views of the model.

### How To: Use the SteeringWheel

1. In the Navigation Bar, expand  (Full Navigation Wheel) and select a SteeringWheel.
  - Alternatively, you can expand  (Steering Wheel) in the Navigation Bar or type **navswheel** in the command line.
2. In the SteeringWheel, hover the cursor over the navigation command that you want to use.
3. Click and hold the mouse button to start the navigation command.
4. Move the cursor to change the view as required.
5. Release the mouse button to end the navigation command.
6. Close the SteeringWheel.
  - The SteeringWheel follows the cursor in the drawing window. Verify that the cursor is positioned correctly before launching a navigation command.

### Full SteeringWheels

You can select from three different full wheels: Full Navigation, View Object, and Tour Building. The Full Navigation wheel includes all of the navigation tools, the Basic View Object wheel contains **Center**, **Zoom**, **Rewind**, and **Orbit**, and the Basic Tour Building wheel contains **Forward**, **Look**, **Rewind**, and **Up/Down**. The full wheels are shown in Figure 1–21.

To close the SteeringWheel, press <Esc> or <Enter> or click the **X** in the SteeringWheel.



Full Navigation

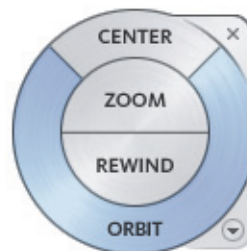

Basic View Object



Basic Tour Building

Figure 1–21

## Mini Wheels

The mini wheels provide access to similar commands as the full wheels, but use a smaller icon with pie-shaped wedges. As the icon moves with the cursor (while you are in the **SteeringWheel** command), the mini wheels provide more screen space by eliminating the text descriptions on the wheel. The mini wheels and their commands are shown in Figure 1–22.

*Right-click on the SteeringWheel to change between the different types of wheels.*

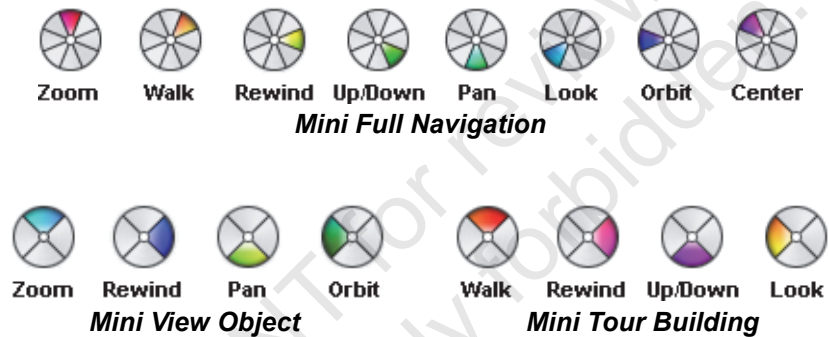

Figure 1–22

## Rewind Command

Use the **Rewind** command to navigate to previously displayed views of the model, as shown in Figure 1–23.



Figure 1–23

## How To: Use the Rewind Command

1. Start the **SteeringWheel** command.
2. Hover the cursor over the **Rewind** option.
3. Click and hold the mouse button to start the **Rewind** command. A series of thumbnails display.
4. Move the cursor over the thumbnails to navigate to the highlighted view. The model updates as you move over the thumbnails.
5. Release the mouse button to make the highlighted view active.

## SteeringWheel Settings

The SteeringWheels Settings dialog box controls the appearance of the SteeringWheels. With a SteeringWheel active, right-click and select **SteeringWheels Settings...** to open the dialog box, as shown in Figure 1–24.

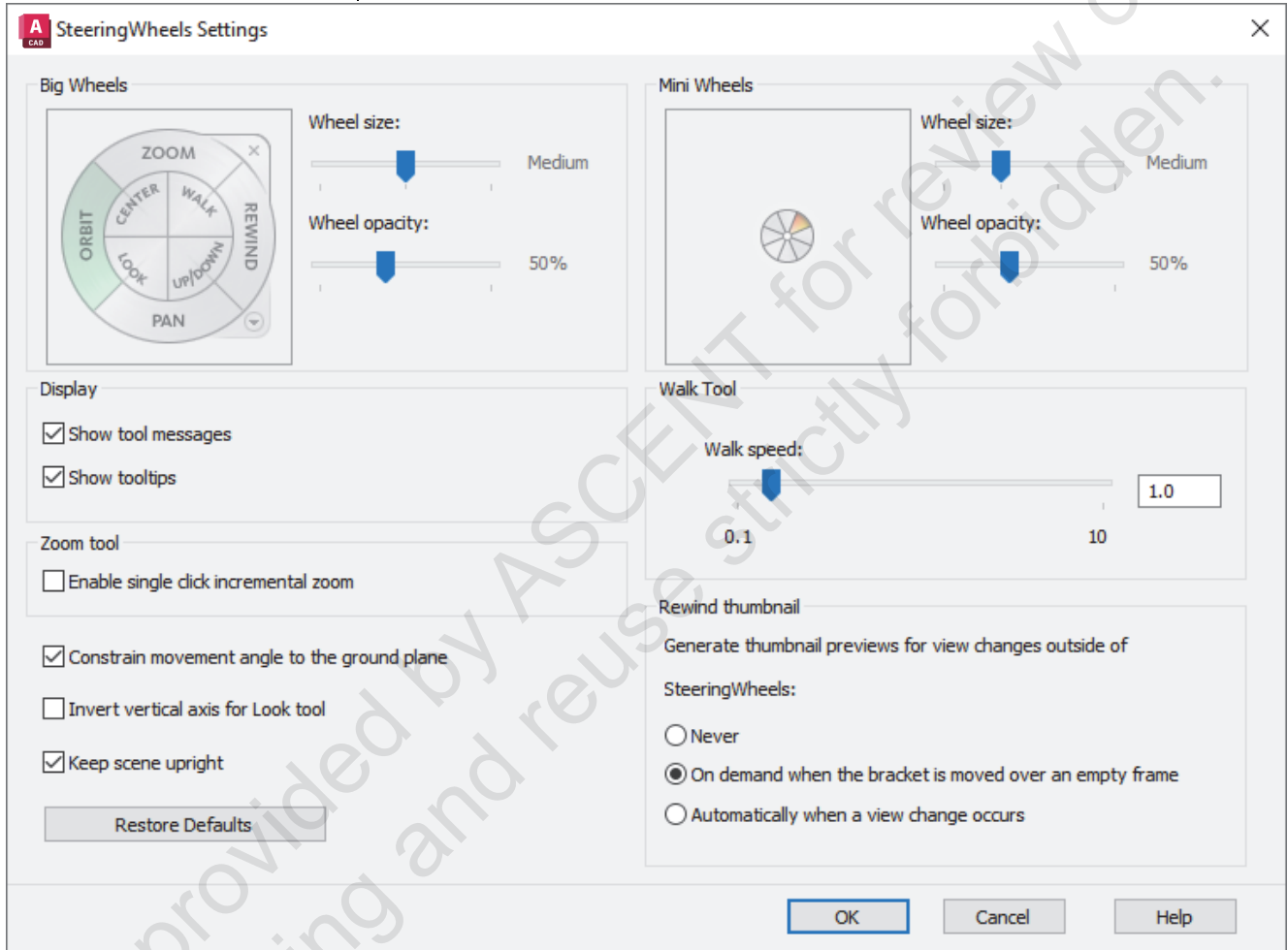

Figure 1–24

## Practice 1a

# 3D Navigation Tools

### Practice Objectives

- Navigate around a 3D model using preset views, manual orbiting tools, ViewCube, and the SteeringWheel.
- Modify the display and appearance of a 3D model by changing the visual style.

In this practice, you will access preset views, orbit the drawing, and test visual styles. You will also use the ViewCube and SteeringWheel to view the drawing. You can use an architectural drawing (as shown in Figure 1–25) or a mechanical drawing (as shown in Figure 1–26).

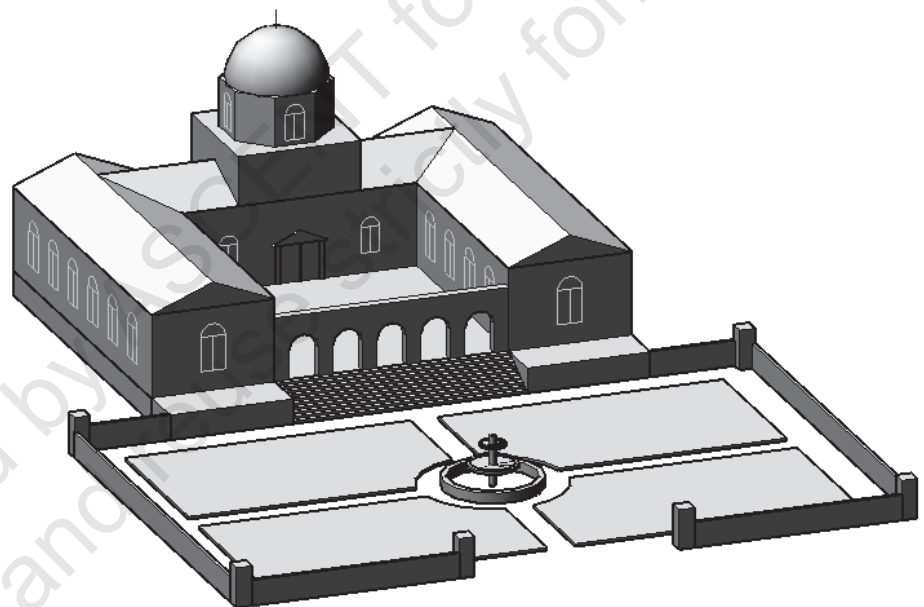

Figure 1–25

### Task 1 - Navigate the model.

1. Open **3D-Solid-Nav.dwg** (mechanical) or **Museum-Concept.dwg** (architectural).
2. In the Status Bar>Workspace Switching list or in the Quick Access Toolbar>Workspace drop-down list, select **3D Modeling**.
3. In the *Home* tab>View panel, use the view presets to display several views of the part or building (Left, Right, SE Isometric, etc.). Finish by selecting the **Top** view to reset the UCS and then select an isometric view.

*You can also select the various views in the **View Controls** drop-down list in the drawing window.*



You can also select the various visual styles in the **Visual Style Controls** list in the drawing window.

4. Hold <Shift> + the middle mouse wheel to use **3DOrbit** and move around the part or building, displaying the different sides.
5. In the *Home* tab>View panel, change the different visual styles to display different appearances for the part or building (Realistic, Conceptual, etc.).

---

### Task 2 - Work with the ViewCube

---

1. Use the ViewCube and navigate to different views using the various sides and corners of the cube.
2. Click  (Home) to return to the **Home** view.
3. Hold <Shift> + the middle mouse button and orbit to a different view. The ViewCube follows the direction of the cursor.
4. Right-click on the ViewCube and select **Set Current View as Home**.
5. Use the ViewCube to change the view and click  (Home) again. It returns to the view you specified as Home.
6. In the drawing window, select the *Visual Style Controls* label and select **Top**.

---

### Task 3 - Use the SteeringWheel.

---

1. In the Navigation Bar, expand  (Full Navigation Wheel) and select **Mini Full Navigation Wheel**.
2. Zoom, orbit, and pan using the SteeringWheel tools, as shown with the mechanical part in Figure 1–26.

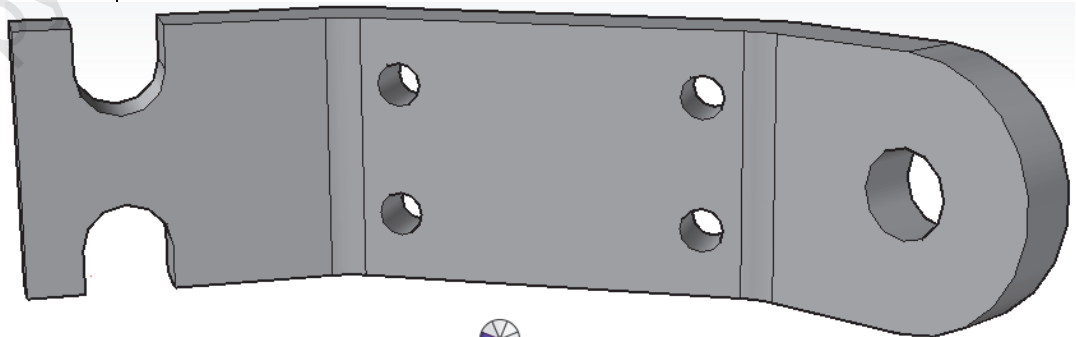

**Figure 1–26**



3. Rewind back to your first view.
4. Right-click on the SteeringWheel, expand Basic Wheels, and select **View Object Wheel**.
5. Try the viewing tools in this SteeringWheel.
6. Right-click again and select **Mini View Object Wheel**. Change the view using this SteeringWheel.
7. Change to one of the other mini wheels and try any tools you have not yet used, such as **Walk** or **Look**.
8. When you have finished trying the new tools, right-click and select **Go Home**. The view returns to the last specified home.
9. Right-click and select **Close Wheel**.
10. Save the drawing.

---

#### Task 4 - Set up the model space with multiple viewing angles.

---

1. Open **Museum-Concept.dwg**, if not already open.
2. In the *Visualize* tab>Model Viewports panel, expand  (Viewport Configuration) and select the **Four: Equal** configuration, as shown in Figure 1–27.

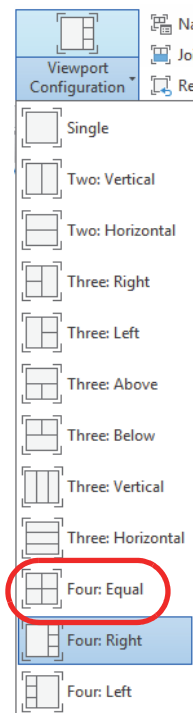

**Figure 1–27**

3. Click inside each viewport and change the viewing angles to the preset views shown in Figure 1–28. (The visual style is set to **2D Wireframe**.)

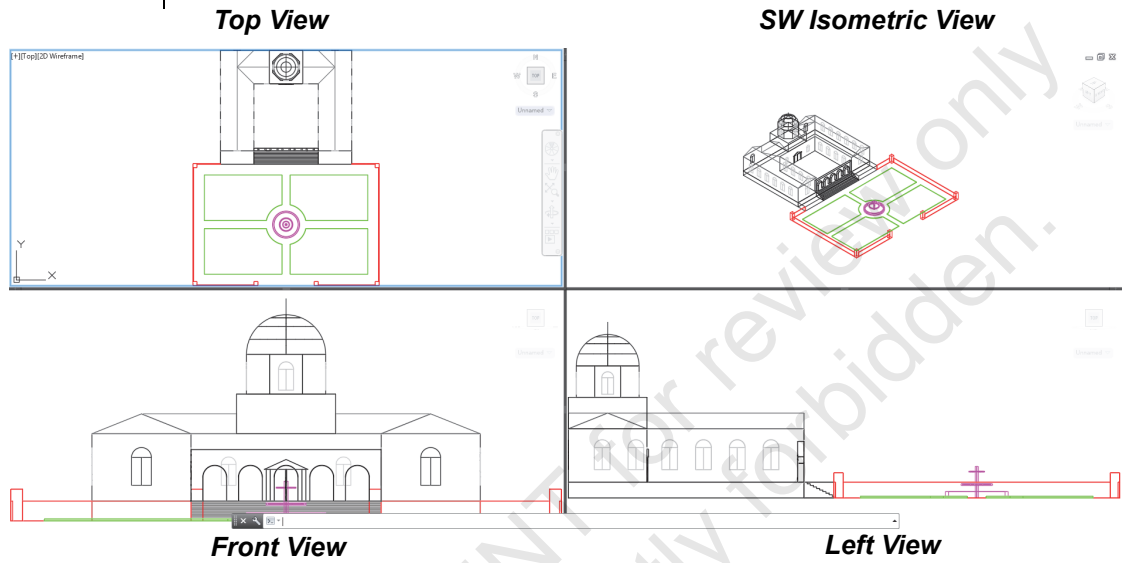

**Figure 1–28**

4. Close the drawing without saving.

## 1.5 Introduction to the User Coordinate System (UCS)

In the AutoCAD software, 2D objects are created on a single flat plane, which is usually the XY plane. In 3D, you can work on the XY plane or change to another plane, as shown in Figure 1–29.

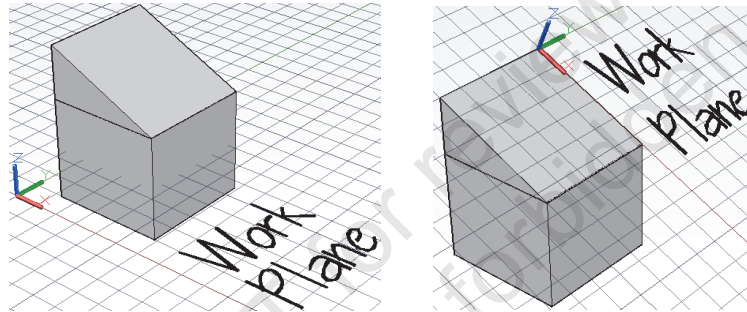

Figure 1–29

There are three axes: the X-axis, Y-axis, and Z-axis. Three planes are also automatically created by the intersections of these axes. They are the XY plane, the YZ plane, and the XZ plane. Together these three axes and their planes make up a user coordinate system, or UCS. The UCS is a user-defined working plane with X,Y coordinates that can be positioned at any location or orientation in space.

When you draw on the UCS, you can use the same commands and methods regardless of the angle or location to which the XY plane has changed. Drawing in 3D is very similar to drawing in 2D. The only difference is that you add information for the Z-direction as well for the thickness, elevation, or height. Many 2D commands can be used to start or add to 3D drawings.

- Do not confuse the UCS position with the viewing direction. The position from which you view your drawing, known as the viewpoint, determines how you see your drawing. The UCS determines where you are drawing. It sets the position of the working plane.
- Each viewport can have its own UCS.

## Modeling with Dynamic Feedback

Most of the 3D commands display dynamic feedback as you draw. Not only can you select points to define the dimensions of the object, including its height, but this information also displays in the drawing window as you work. You can type specific numbers or select points with the cursor, as shown in Figure 1–30.

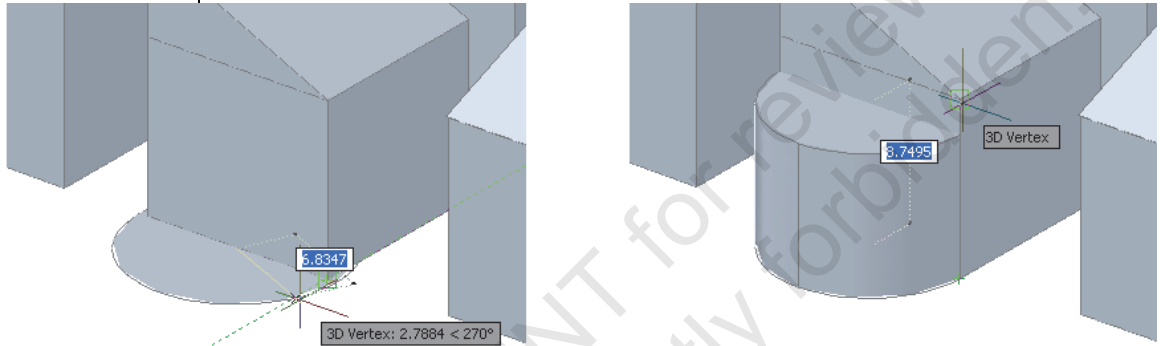

Figure 1–30

- POLAR, OTRACK, and ORTHO work with dynamic input in the Z-axis direction.

## Dynamic UCS

Rather than frequently changing the UCS, you can use the **Dynamic UCS (DUCS)** command to temporarily move the UCS to a face on a 3D object while you are drawing, as shown in Figure 1–31. While you are in a command, move the cursor over the edge of a face until it is highlighted, and then proceed with the command. The UCS icon moves to that face and the next objects created align with the coordinate system of the face. When the command is finished, the UCS returns to its previous location.

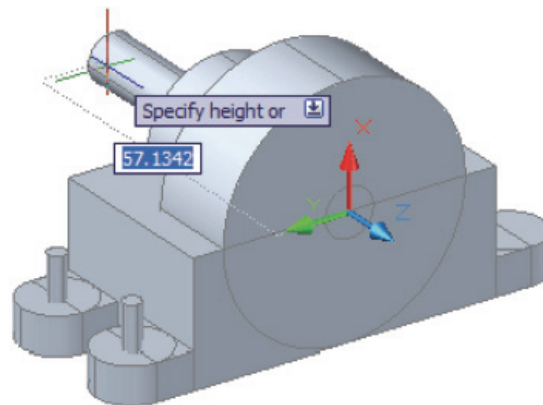

Figure 1–31



- The Dynamic UCS can be toggled on and off by clicking  (Dynamics UCS) in the Status Bar, as shown in Figure 1–32.



Figure 1–32

- When the cursor is moved over to a face, the crosshair takes the orientation of the edge (side) over which the cursor was being passed.
- Object Snaps can be used with **Dynamic UCS**. Sometimes, object snaps can interfere with the selection when you are identifying the face you want to use. Toggle off  (Object Snap) in the Status Bar or press <F3> until you have selected the face you want to use. You can also use the **None** Object Snap Override to temporarily toggle off Object Snap.
- You can use 3D object snaps by toggling on  (3D Object Snap) in the Status Bar. They include: **Vertex**, **Midpoint on edge**, **Center of face**, **Knot**, **Perpendicular**, and **Nearest to face** and are useful when snapping to points on 3D objects.
- To change the current UCS to a different face in the drawing, start the **UCS** command, select the face, and press <Enter>. The UCS moves to the selected face. If the grid is on, it aligns with the new UCS as well.
- The World Coordinate System is the drawing's original and master coordinate setup. Type **UCS** and select **World** to restore the drawing coordinates to the master coordinate system.







## Practice 1b

# Introduction to the User Coordinate System

### Practice Objective

- Add 2D objects to various faces on a 3D model using Dynamic UCS.

In this practice, you will add 2D objects to a simple solid model using Dynamic UCS, and view the model with 3D Navigation commands.

1. Open **DUCS.dwg**.
2. In the Status Bar, toggle on  (Grid Display),  (Dynamic UCS),  (Dynamic Input), and  (Lineweight), if they are not already on.
3. In the Status Bar, toggle off  (Object Snap) and  (3D Object Snap).
4. Orbit the model to display the faces labeled A, B, C, D, and E. Finish with a view in which Face A displays.
5. In the *Home* tab>Draw panel, click  (Line). Hover over Face A until it highlights and add several lines to the surface, similar to those shown in Figure 1–33.

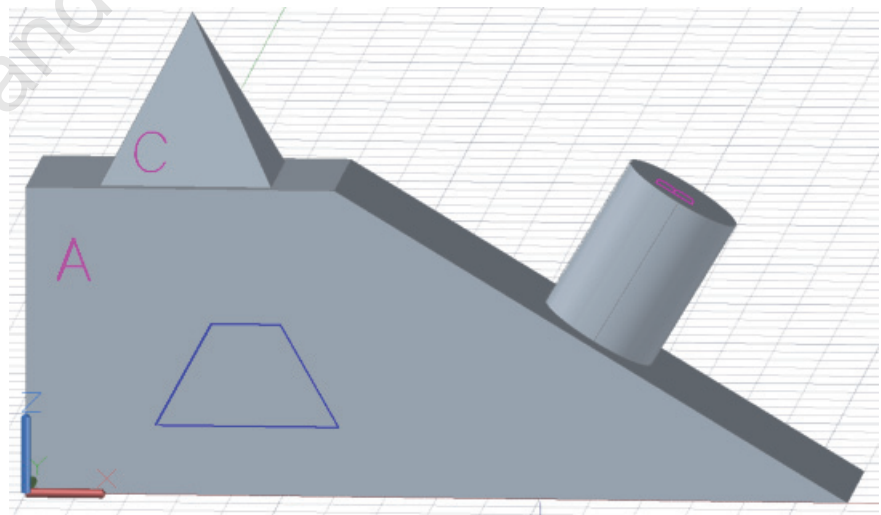



Figure 1–33

6. Click  (Circle). Hover over Face B until it highlights. Draw a small circle anywhere on Face B, similar to that shown in Figure 1–34.
7. Draw another circle on Face C, similar to that shown in Figure 1–34.

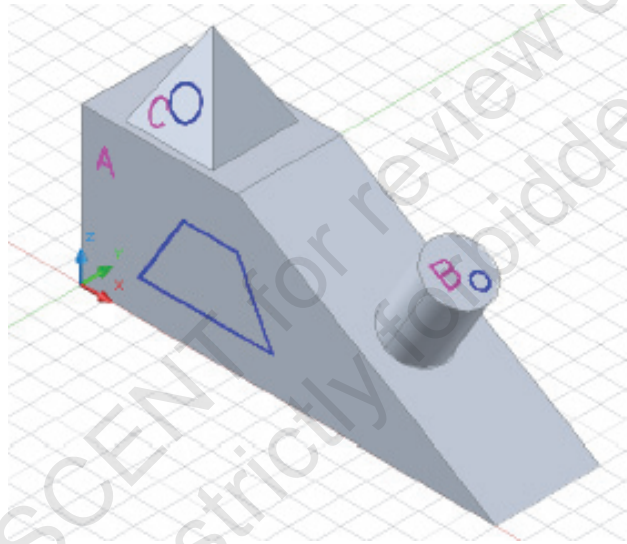

Figure 1–34

8. Orbit the model to display Faces D and E. Draw objects on those faces.
9. Finish with the **SE Isometric** view and save the drawing.

## Chapter Review Questions

1. Which of the following is a type of 3D model?
  - a. Cone
  - b. Mesh
  - c. Box
  - d. Cylinder
2. The *Visualize* tab contains tools that enable you to add lights and materials to the model.
  - a. True
  - b. False
3. Which of the following is a preset 3D view?
  - a. SW Isometric
  - b. Top
  - c. Front
  - d. All of the above
4. When using the ViewCube to view a model in 3D, which of the following icons near the ViewCube can you click to return to the original view?
  - a. **Top**
  - b. **WCS**
  - c. **W**
  - d. **Home**
5. Which of the following is true of the Dynamic UCS?
  - a. When you move the UCS to a selected face on a 3D object, it remains there permanently.
  - b. It cannot be used with object snaps.
  - c. It cannot be toggled on or off.
  - d. Temporarily moves the UCS to a selected face on a 3D object.













6. A perspective view helps you to evaluate the object's shape and size proportions without any distortion, while a parallel view gives you a better sense of space and depth.
- True
  - False

Sample provided by ASCENT for review only  
All copying and reuse strictly forbidden.

# Command Summary

All ribbon names reference the 3D Modeling workspace.

Button	Command	Location
	<b>Allow/Disallow Dynamic UCS</b>	<ul style="list-style-type: none"> <li>• <b>Status Bar</b></li> </ul>
	<b>Continuous Orbit</b>	<ul style="list-style-type: none"> <li>• <b>Ribbon:</b> <i>View</i> tab&gt;Navigate panel</li> <li>• <b>Navigation Bar</b></li> </ul>
	<b>Free Orbit</b>	<ul style="list-style-type: none"> <li>• <b>Ribbon:</b> <i>View</i> tab&gt;Navigate panel</li> <li>• <b>Navigation Bar</b></li> </ul>
	<b>Home</b>	<ul style="list-style-type: none"> <li>• <b>ViewCube</b></li> </ul>
	<b>Orbit</b>	<ul style="list-style-type: none"> <li>• <b>Ribbon:</b> <i>View</i> tab&gt;Navigate panel</li> <li>• <b>Navigation Bar</b></li> </ul>
	<b>Preset Views</b>	<ul style="list-style-type: none"> <li>• <b>Ribbon:</b> <i>Home</i> tab&gt;View panel</li> </ul>
	<b>SteeringWheel</b>	<ul style="list-style-type: none"> <li>• <b>Ribbon:</b> <i>View</i> tab&gt;Navigate panel</li> <li>• <b>Navigation Bar</b></li> </ul>
	<b>User Interface</b>	<ul style="list-style-type: none"> <li>• <b>Ribbon:</b> <i>View</i> tab&gt;User Interface panel</li> </ul>
<b>N/A</b>	<b>ViewCube Display</b>	<ul style="list-style-type: none"> <li>• <b>Ribbon:</b> <i>View</i> tab&gt;User Interface panel&gt;User Interface drop-down list</li> </ul>
	<b>Visual Styles</b>	<ul style="list-style-type: none"> <li>• <b>Ribbon:</b> <i>Home</i> tab&gt;View panel or <i>View</i> tab&gt;Visual Styles panel</li> </ul>
	<b>Workspace Switching</b>	<ul style="list-style-type: none"> <li>• <b>Quick Access Toolbar</b></li> </ul>
		<ul style="list-style-type: none"> <li>• <b>Status Bar</b></li> </ul>